



State-of-the-Art Pointing Solutions for the OEM

MicroModule™



Integration Guide

Version 5.0

- Complete turnkey solution
- Easy to integrate
- Compact – fits anywhere
- Sealable design
- Durable – no moving parts
- USB, RS232C, PS/2 and TTL

INTERLINK
ELECTRONICS



516 Flynn Road • Camarillo, CA 93012
(805) 484-1331 • Fax (805) 484-8389
www.interlinkelectronics.com

Table of Contents

1.0	Introduction to MicroModule™	1
2.0	Operating MicroModule	2
2.1	Using the Pressure-Sensing Actuator	2
2.2	Clicking and Dragging	2
3.0	Integration Notes	3
3.1	Mounting and Sealing MicroModule	3
3.2	Electrical Interfacing to MicroModule	4
3.2.1	Standard MicroModule	4
3.2.2	USB MicroModule	6
3.3	Configuration Jumpers.....	7
3.4	Cabling Options	9
4.0	Custom Designs	11
5.0	Technology	12
6.0	Product Specifications	13
7.0	Drawings	
Figure 7.1	Mouse Button Module Detail	14
Figure 7.2	Mini Joystick Module Detail.....	15
Figure 7.3	Printed Circuit Board Detail	16
Figure 7.4	Suggested Mounting Cut-Out	17
Figure 7.5	Mouse COM Port Output	18
Figure 7.6	DB-9, PS/2 and USB Connector Detail.....	19
Figure 7.7	Optional Cable Details	20
Figure 7.8	MicroModule PCB Schematic	21
Figure 7.9	USB MicroModule PCB Schematic	22
8.0	Warranty Information Product Support	23
9.0	Product Support	24

Version 5.0 ©2000 Interlink Electronics, Inc.
Publication Number: 90-45447 Rev. D

VersaPoint is a registered trademark of Interlink Electronics, Inc. MicroModule is a trademark of Interlink Electronics, Inc. IBM, OS/2 and PS/2 are registered trademarks of International Business Machines Corp., Windows, Windows 95 and MS-DOS are trademarks of Microsoft Corporation. All other trademarks are the property of their respective owners.

1.0 Introduction

Introduction to MicroModule^ä

Thank you for purchasing Interlink Electronics' MicroModule. Designed for OEM integration, MicroModule pointing solutions are ideal for computer cursor control in rugged mobile computers, hardened keyboards, navigation systems, machine control panels, and many other computer pointing applications. MicroModule's standard data outputs allow easy interfacing to other control applications such as pan and tilt controllers, motion controllers, CNC controllers and medical control equipment.

MicroModule is available with a choice of two actuator styles, either a Mouse Button (a round disk with a fingertip-shaped divot), or a Mini Joystick (a compact control stick). Both actuator styles deliver simultaneous 360° control of direction and speed with the touch of a fingertip. All MicroModule pointing solutions are maintenance free and deliver "mouse" lifetimes in excess of 5 million actuations.

MicroModule requires less than 0.25" of mounting depth (much less than trackballs or joysticks), allowing it to be easily integrated into tight, cramped spaces. MicroModule's slim mounting profile and small front-panel mounting area frees valuable space for other system components. MicroModule is unaffected by mounting orientation: it can be mounted horizontally, as in a desktop keyboard; vertically, as on a machine control panel; or any angle in between. This gives system designers maximum flexibility with product design and ergonomics.

MicroModule's silicone-rubber actuators are designed with an integrated sealing rib that permits MicroModule to be sealed into a system during installation. Common silicone sealant or mounting brackets can also be used to create a watertight seal. Once sealed into a system, spills, rain, or humidity will not affect MicroModule's performance--making it ideal for field service, outdoor, or hose-down environments.

MicroModule incorporates Interlink Electronics' VersaPoint® Pressure-Pointing technology. Directional control is achieved by applying pressure in the direction of desired movement. Speed is controlled by altering the amount of applied pressure. The result is smooth cursor movement in any direction, from a precise crawl to a screen-crossing zip. VersaPoint technology has no moving parts to break or wear out, thus delivering reliable, trouble-free cursor control.

Before using or installing MicroModule, please take a few minutes to carefully review this Integration Guide.

2.0 Operating MicroModule

2.1 Using the Pressure-Sensing Actuator

MicroModule's pressure-sensing actuators (Mouse Button or Mini Joystick) convert the touch of a finger into smooth cursor movement. To move the computer cursor or other device being controlled by MicroModule (e.g., a closed-caption camera), place your fingertip on the center of the actuator and rock it in the direction you want the cursor to move. You can move the cursor in any direction--MicroModule has full 360° directional control. A light touch will produce precise cursor movement. Increases in pressure will increase the speed--the harder you press, the faster the motion.

Hint: For maximum performance and flexibility in Windows, we recommend that you use the VersaPoint Windows mouse driver. Please see the *VersaPoint Software User's Guide* or contact Interlink Electronics Product Support for more information.

2.2 Clicking and Dragging

To Click

The click buttons are located on either side of the actuator and operate like those on a conventional mouse. The left button on the MicroModule is equivalent to the left mouse button and is used as the default primary button. The right button is equivalent to the right mouse button and is used as the default secondary button. You can interchange the operation of the buttons in the Windows or VersaPoint Mouse Control Panel, if desired (e.g., for left-handed users).

To Drag an Item

Simply press and hold the primary button while moving the cursor with the actuator. Release the primary button to complete the drag operation. Some users find it easier to swap click buttons and use the right click as the primary button, allowing fore-finger cursor control with middle-finger clicking.

Programmable Drag Lock

The VersaPoint Windows mouse driver for RS232C and PS/2 mode has a programmable drag-lock feature. Once this feature is activated (e.g., by programming the right click button to activate the drag-lock feature) an object remains selected until a click button is depressed. This facilitates simple one-finger clicking-and-dragging. For more details on this feature, please refer to the *VersaPoint Software User's Guide*.

3.0 Integration Notes

3.1 Mounting and Sealing MicroModule

MicroModule is designed to be blind-mounted into a variety of panel types. Additionally, custom bezels can be fabricated or molded to allow integration into devices such as machine control panels or notebook computers.

Suggested Panel Cut-out

When mounting MicroModule, the suggested clearance for the cut-out around the actuator (Mouse Button or Mini Joystick) is 0.02” (0.5 millimeters) and 0.04” (1.0 millimeters) for the click buttons. See Figure 7.4 for details on the suggested cut-out. Additionally, direction jumpers have been included to allow MicroModule to be mounted horizontally or vertically (see section 3.3, Configuration Jumpers). The default mounting orientation of MicroModule is shown in Figure 7.3.

Mounting MicroModule

To panel mount the module without sealing, provide panel designed with the necessary cut-outs for the actuator and click buttons, and four or more fasteners (e.g., PEM studs, edge clips, hole clips, heat stakes, etc.). When installing, MicroModule should be seated evenly and the fasteners tightened evenly to avoid stressing the printed circuit board. Over torque on the bolts should be avoided. This could crack the PCB and cause the module to fail. With proper seating and tightening, a liquid and particulate resistant interface can be created.

The FSR is connected to the PCBA with Z-axis adhesive. This is an electrical, not mechanical, bond. A mechanical means of applying a compressive force to the joint should be incorporated in the mounting of the MicroModule. This will prevent the delamination of the adhesive, which can lead to an open circuit. For example, a rib could be designed into the assembly to apply pressure to the joint. Rubber could be used on the end of the rib to take up tolerances in the design.

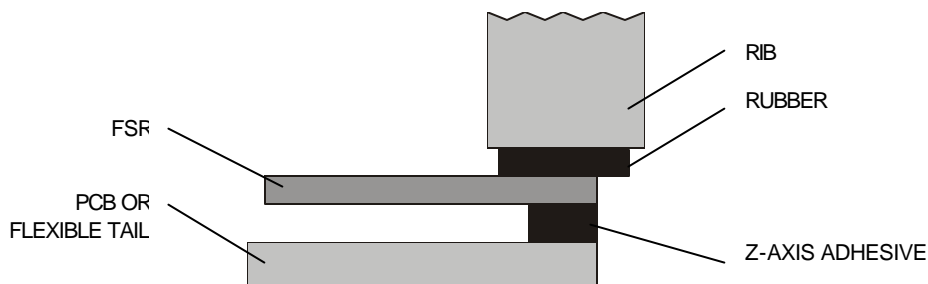

Using a Rib to Compress the Adhesive Joint

Supporting MicroModule's PCB

A mounting bracket/clip may be added during installation of MicroModule to support its PCB. This is suggested in applications where MicroModule may be subjected to heavy impact blows or large stresses. The mounting bracket/clip should be designed to mount around the edge of the PCB and should help prevent excessive flex in the PCB.

Sealing MicroModule with Silicone Sealant

Some integrators may want to completely seal MicroModule into a system (e.g., for a NEMA 4X seal). RTV silicone sealant can be used as a sealing material. Before starting installation, be sure to clean the panel and rubber keypad thoroughly with isopropyl alcohol. Integrators may also find that some panel/bezel materials will need to be primed with a silicone primer to obtain proper adhesion. To seal MicroModule with silicone sealant, apply a thin bead of sealant to the top of the rubber keypad on the outer edge of the keypad's sealing rib. Minimize the amount of sealant applied to prevent lumping near the active buttons, which could adversely affect the MicroModule's performance. Alternately, sealant can be applied around the perimeter of the module and the bolt holes after it has been mounted into the bezel or panel. For the best possible seal, apply the sealant to both the top of the keypad before installation, and around the perimeter of the module after installation.

Sealing MicroModule with a Mounting Bracket/Clip

Alternatively, MicroModule may be completely sealed into a system with the addition of a mounting bracket/clip. The bracket/clip should be designed to apply even sealing pressure around the edge of MicroModule's PCB. This will help compress the sealing rib and ensure that the seal is moisture- and dust-proof.

3.2 Electrical Interfacing to MicroModule

There are two choices of PCBA available for the MicroModule, based on connectivity.

3.2.1 RS232C and PS/2 MicroModule

The Standard MicroModule can be connected to either a Microsoft-compatible serial interface (RS232C or direct TTL) or a PS/2 mouse-port interface. The CON1 PCB header allows interfacing at RS232C levels or to a PS/2 port, and the CON2 header allows direct serial interfacing at TTL levels (see Figure 7.3 for more information on header locations). Before installing MicroModule, first verify that your system meets these requirements:

- IBM PC-compatible system, or a workstation with a PS/2 mouse port
- COM1 or COM2 serial port, PS/2 mouse port or direct UART serial interface available
- MS-DOS Version 2.0, Windows 3.0, 95, 98, NT, 2000, OS/2 Version 2.0 or newer, or operating system with Microsoft-compatible mouse driver via serial or PS/2 interface. All other systems via PS/2 port only.

Note: Before installing MicroModule, be sure that the system is powered down.

RS232C Serial Interface Connections

The following table shows the pin-out for RS232C serial data connections to the CON1 header. CON1 is the 8-pin, 1.25 millimeter-center header on the back of MicroModule's circuit board. Also shown are the connections for a standard 9-pin DB-9 serial connector. Five lines are needed for an RS232C serial connection.

Serial, RS232C Level, Pin-Out Information

CON1 Pin	Signal	Signal Description	DB-9 Pin*
1	GND	Ground	5
2	RTS	Request to send	7
3	DTR	Data terminal ready	4
5	TXD	Transmit data	3
6	RXD	Receive data	2

* See Figure 7.6 for details on the DB-9 pin-out convention

MicroModule uses standard Microsoft-compatible serial-data format. In order for MicroModule to properly communicate to a system, a Microsoft-compatible mouse driver, such as the supplied Windows VersaPoint mouse driver, will need to be installed (see the VersaPoint Software User's Guide). Once MicroModule is connected, the correct mouse driver is installed, and the system restarted, MicroModule will operate properly.

PS/2 Mouse Port Connections

The following table shows the pin-out of connector CON1 that corresponds to a PS/2 mouse port connection. Also shown are the connections for a standard 6-pin mini-DIN PS/2 mouse-port connector. Four lines are needed for a PS/2 connection.

PS/2 Pin-Out Information

CON1 Pin	Pin	PS/2 Pin*
1	Ground	3
4	Vcc	4
7	Clock	5
8	Data	1

* See Figure 7.6 for details on the PS/2 pin-out convention

TTL Level Serial Connections

CON2, located at the opposite end of the PCB from CON1, is the connector site for MicroModule's direct serial interface. CON2 outputs are at TTL levels. Four lines are needed for a direct serial connection. The following table shows the pin-out of header at CON2 and gives details on the TTL signals.

Direct Serial, TTL, Pin-Out Information

CON2 Pin	Signal	Signal Description
1	GND	Ground
2	Vcc	Vcc (5V or 3.3V)
3	RXD	Receive data
4	RTS	Request to send

3.2.2 USB MicroModule

The USB MicroModule can be connected directly to a USB interface. (See drawing 7.3 for the information on header location). Before installing the USB MicroModule, verify that your system meets these requirements:

- IBM PC-compatible system with a USB port
- Windows[®] 98 or Windows 2000

The USB MicroModule is a hot plug-unplug, plug-and-play device. You can plug in the USB MicroModule without having to power down the system. The USB MicroModule is also a plug-and-play device. It uses a Windows 98 or Windows 2000 standard mouse driver. Once you plug in the USB MicroModule, the operating system will automatically detect a USB device. Follow the instructions to install the Windows standard mouse driver and the USB MicroModule will operate properly.

USB Serial Interface Connections

The following table shows the pin-out for USB serial data connections to the J2 header. J2 is the 8-pin, 1.25 millimeter-center header on the back of the USB MicroModule's circuit board. Also shown are the connections for a standard USB serial connector. Four lines are needed for a USB serial connection.

USB Pin-Out Information

J2 Pin	Signal	Signal Description	USB Contact Number
1	VCC	+5v	4
2	D+	D+	2
3	D-	D-	3
4	GND	Ground	1
NC	Shell	Shield	Shell

See Figure 7.6 for details on the USB pin-out convention.

3.3 Configuration Jumpers

Several configuration jumpers/resistor are located on MicroModule's PC board. These jumpers/resistors allow re-mapping the cursor direction response (up, down, left, and right) and offer selectable cursor speed response settings. The direction jumpers/resistors can be used to keep the cursor orientation consistent with the mounting orientation (e.g., if MicroModule is mounted in a vertical orientation, instead of the default horizontal orientation, the four direction resistors/jumpers can be re-mapped so that the actuator "up" remains "cursor up"). Figure 7.3 details the location of each jumper of standard and USB MicroModules.

Direction Jumpers

Four configuration jumpers are located on MicroModule's PC board component side. Figure 7.3 details the location of each jumper. Jumpers from left to right correspond to the default right, up, left and down cursor movement directions as viewed from the non-component side of the PCB. The cursor orientation of the standard MicroModule can also be changed in Windows with the VersaPoint mouse driver. Refer to the *VersaPoint Software User's Guide* for more information.

To change the cursor orientation of MicroModule, first, disconnect the lower pads from the upper pads by using an X-Acto[®]-style knife to carefully cut the traces connecting the two lower pads to the upper pads. Then, solder wires from the lower pads to the appropriate upper pads.

Note: Use care to not solder close to the vias: the force sensor, located opposite the via on the non-component side of the PCB, can be damaged by excessive heat.

Note: The jumper wires must not protrude through the opposite side of the board. This will cause damage to the force sensor.

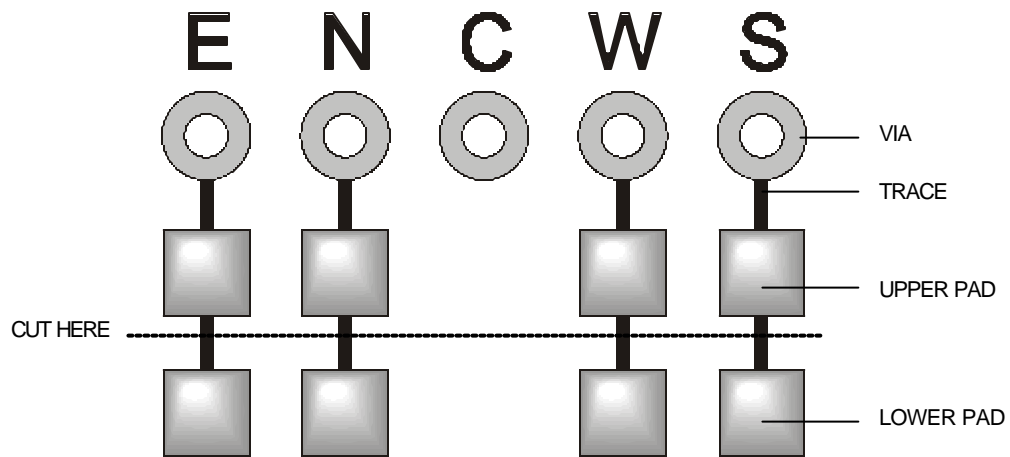

Default Direction Jumper Settings

Configuration Resistors (USB version only)

Four configuration resistors locations are available on the USB MicroModule's PC board. Figure 7.3 details the location of each resistor. The combination of 2 resistors correspond to the default right, up, left and down cursor movement directions as viewed from the non-component side of the PCB. The following table details resistor locations that change the cursor orientation of the USB MicroModule.

Resistors	R7, R8*	R8, R6	R7, R9	R9, R6
Desired Orientation	North	East	South	West

* Default

Speed Jumpers

MicroModule provides three speed ranges: fast, medium, slow. Medium is the default. In this illustration Jumper 3 (JP3) is bridged for the default cursor speed setting of medium:

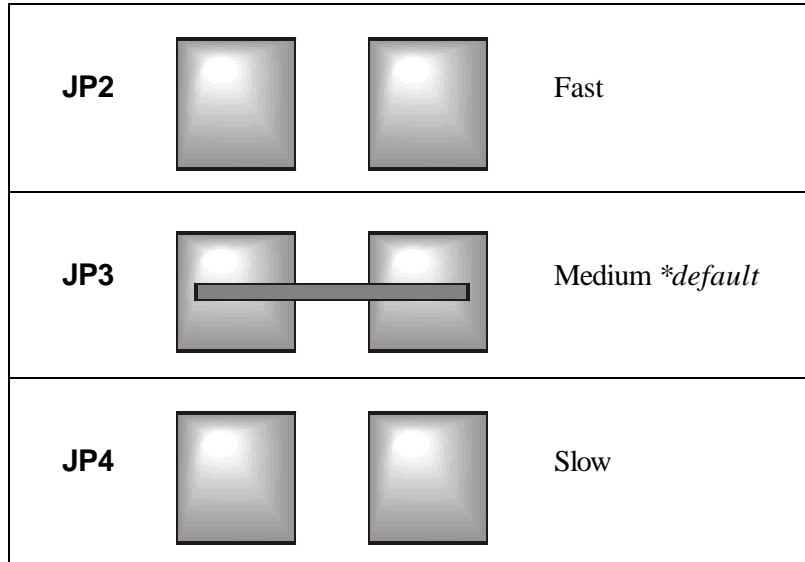

The medium range works well for DOS, Windows and OS/2. The slow setting may be appropriate for “fast” operating systems/interfaces. Integrators are encouraged to optimize the speed range of MicroModule to meet their system’s requirements.

The cursor speed of MicroModule can be changed in Windows with the VersaPoint mouse driver. Refer to the *VersaPoint Software User’s Guide* for more information.

To change the cursor speed of MicroModule on the board, first, carefully remove the solder bridge that connects JP3. Then, solder wires to connect the jumpers associated with the cursor speed you desire. If a different usage response range is needed, please contact Interlink Electronics Product Support. Interlink Electronics can design an optimal speed range for any application.

3.4 Cabling Options

Interlink Electronics offers a variety of cables to interface with MicroModule. Interlink Electronics can also have custom cables fabricated to your specification. If a custom cable is required, please contact Interlink Electronics’ Product Support for more details. Information on the mating connector to MicroModule’s PCB header is given below for system integrators wishing to fabricate cables in-house.

MicroModule Interface Cables

A list of interface cables for MicroModule is given below. More detailed interface cable information can be found in Figure 7.7. These cables are designed to interface with the CON1 and CON2 headers, adapt from a DB-9 serial cable to a PS/2 port, or extend an interface connection.

- **VP615** – 6' PVC USB cable (Molex female connector to USB-type A port connector)
- **VP630** – 6' PVC PS/2 cable (Molex female connector to mini-DIN 6 mouse port connector)
- **VP640** – 6' PVC serial cable (Molex female connector to DB-9 serial connector)
- **VP650** – PS/2 adapter cable (DB-9 serial to PS/2, mini-DIN 6 mouse-port connector)
- **VP660** – 6' PVC serial extension cable (DB-9 male to DB-9 female connector)
- **VP810** – 12" Serial or PS/2 wire harness for CON1 (Female connector to discrete wires)
- **VP820** – 12" TTL wire harness for CON2 (Female connector to discrete wires)

Molex Header/Mating Connector Specifications

The CON1 and CON2 headers are a Molex series #53261. Molex connector series #51021 is designed to mate with this header. The metallic contacts that slip into this housing can be either 50079-8 or 50058-8. The 50079 contacts accept wires AWG 26-28, and the 50058 contacts accept wires AWG 28-32.

4.0 Custom Designs

Interlink Electronics can custom design MicroModule pointing solutions to meet almost any requirement. Such custom solutions might include:

Optional Click Button Types

MicroModule comes standard with integrated elastomeric click switches. These rubber buttons can be removed if more conventional microswitches are preferred. Connecting pads have been included on the PCB for microswitches (see Figure 7.3).

Connector Types

MicroModule comes standard with a Molex 8-pin 1.25 millimeter header. This connector is designed for use with cables and wire harnesses. This connector can be replaced with an optional 8-pin 1.25 millimeter ZIF flex circuit connector for use with flexible circuit cabling.

Backlighting

MicroModule actuators can be molded with a translucent molding compound. If your system requires backlighting, please contact Interlink Electronics Product Support for more information.

Other Options

Interlink Electronics specializes in customizing MicroModule pointing solutions. MicroModule pointing solutions can easily be designed to meet your specifications for size, color, number of buttons, output protocol, graphic design, sensitivity/speed range, extended temperature range, increased chemical resistance, special output header or almost any other requirement. We encourage you to contact Interlink Electronics Product Support for more information.

5.0 Technology

How MicroModule Works

MicroModule's innovative design features no moving parts -- the patented pressure-sensitive sensor used in VersaPoint technology replaces the troublesome mechanical assemblies (optical encoders, wheels, roller, balls, etc.) found in conventional mice and trackballs. MicroModule's rubber keypads can be removed to inspect the different aspects of its design.

When finger pressure is applied to MicroModule's cursor-control actuator, the pressure is transferred to the pressure-sensitive sensor located under the actuator. The sensor is divided into four directional zones (up, down, left, right). The pressure distribution over the four zones determines the direction of cursor movement. This same sensor also controls the speed of cursor movement -- a light touch moves the cursor at a precise crawl while an increase in pressure will cause the cursor to move faster.

MicroModule standard click buttons are elastomeric switches. Small conductive elastomer pads on the back of the keypad shunt exposed electrodes on the surface of the PC board.

MicroModule offers three data formats: Microsoft two-button serial mouse output (RS232C and direct TTL), PS/2 two-button mouse output and USB. It is plug-and-play with DOS, Windows, and OS/2 operating systems via the serial and PS/2 ports, all other operating systems via the PS/2 port, and Windows 98, 2000 and Millennium via the USB port.

For enhanced operation in Windows, a VersaPoint Windows mouse driver is available, and is included with the MicroModule Starter Kit. While it provides optimal performance, the standard Microsoft mouse driver included with Windows also works well. A VersaPoint DOS mouse driver is also included for DOS applications.

6.0 MicroModule Specifications

Hardware Interfaces:	USB, RS232C serial, PS/2 mouse port, or direct serial TTL levels
Output Data Formats:	Microsoft, PS/2 two-button mouse, USB
System Compatibility:	DOS, Windows, OS/2 via serial and PS/2. PS/2 compatible with any PS/2 port (X-terminals, etc.) USB MicroModule works with Windows 98, Windows 2000 or Windows Millennium only.
Cursor Directional Control:	Continuous 360° control
Cursor Speed Control:	Proportional to applied pressure
Power Consumption:	<6 mA at 5V DC and <3 mA at 3.3V DC <20mA for USB
Weight:	<15 grams
Liquid/Dust Resistance:	Complete when sealed into system*
Mounting Options:	PEM studs, heat staking, fasteners, etc.
Lifetime:	Mouse actuator: > 5 million cycles
Primary Material:	Silicone rubber keypad
Chemical Resistance:	Soap, alcohol, bleach, oil, saline, Cidex 7, etc.
Temperature:	Operating: +32°F to +158°F (0°C to +70°C) Storage: -40°F to +185°F (-40°C to +85°C) (Extended temperature ranges available)
Shock:	80G acceleration, 11msec, half-sine*
Vibration:	MIL STD 202, Method 204, Condition A*
EMI:	FCC Rule 15, Class B Certifiable*
ESD Susceptibility:	IEC 801-2, Level 4 (no errors at 15kV)*
Optional Cables:	<ul style="list-style-type: none">• 6-ft. PVC cable, PCB connector to DB-9 serial• 12" Wire harness, PCB connector to discrete wires• PS/2 adapter cable, DB-9 serial to PS/2• 6-ft. PVC extension cable, DB-9 serial male to female• 6-ft. PVC cable, PCB connector to USB type A

* When properly integrated

7.0 Drawings

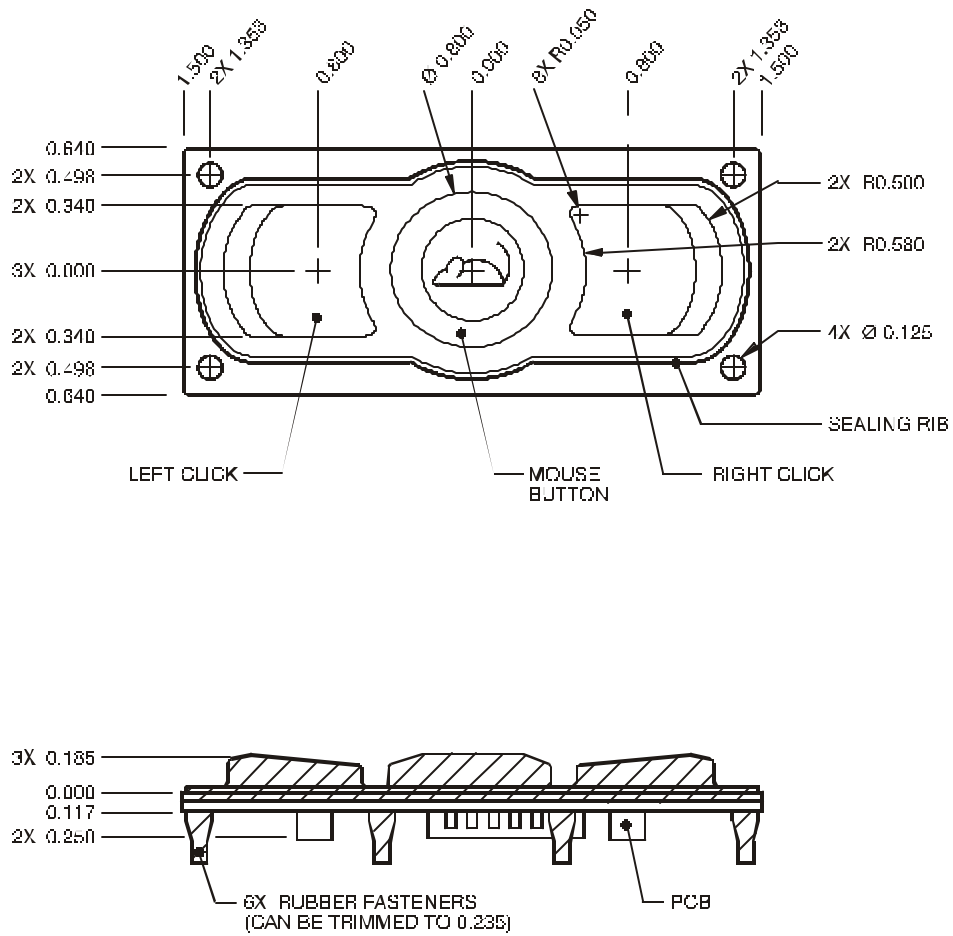

Figure 7.1
Mouse Button Module Detail

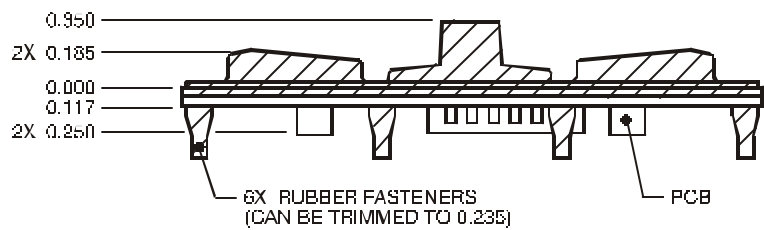
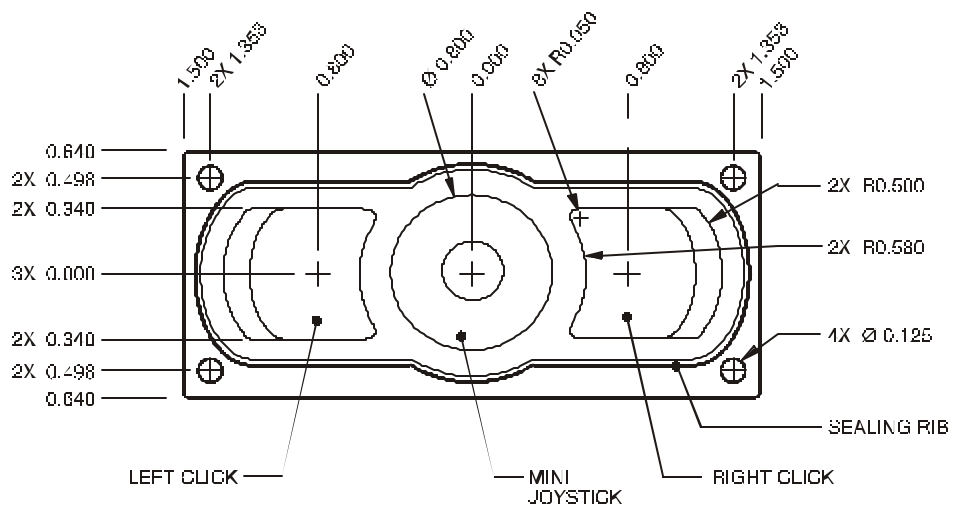

Figure 7.2
Mini Joystick Module Detail

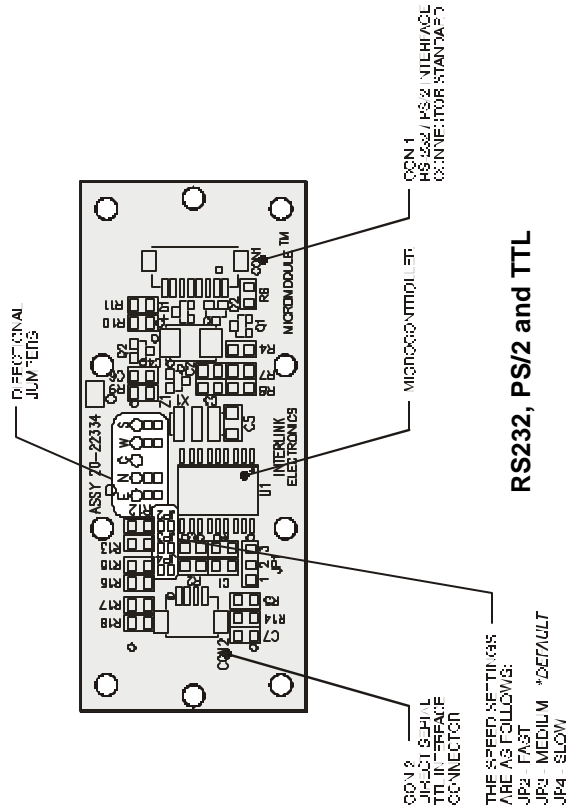
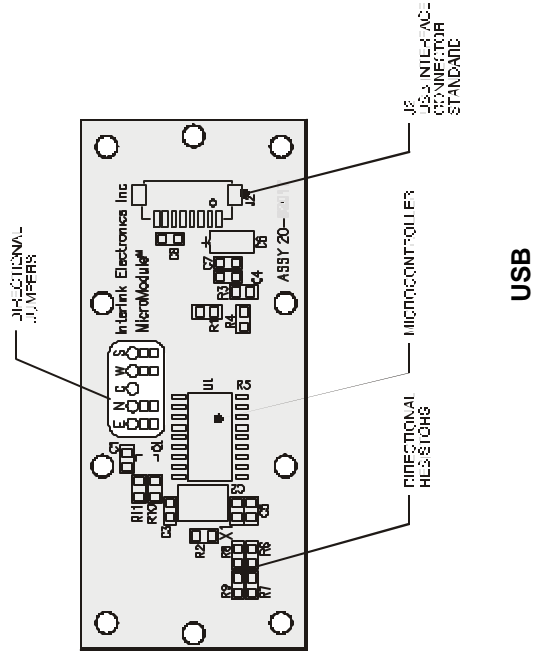
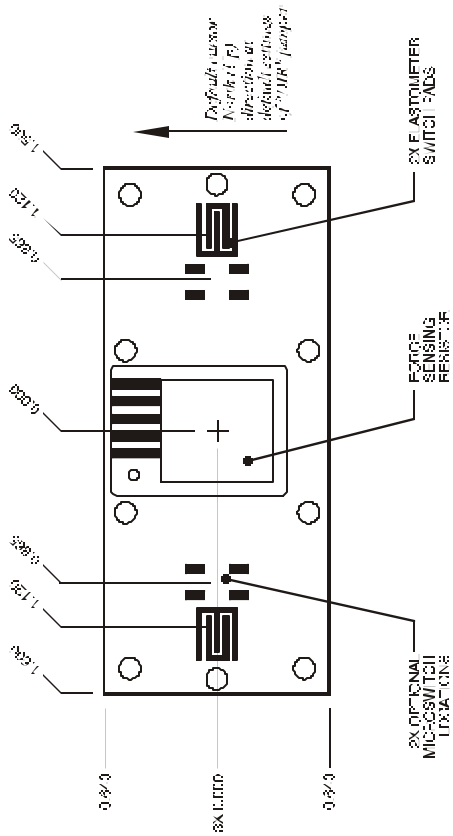
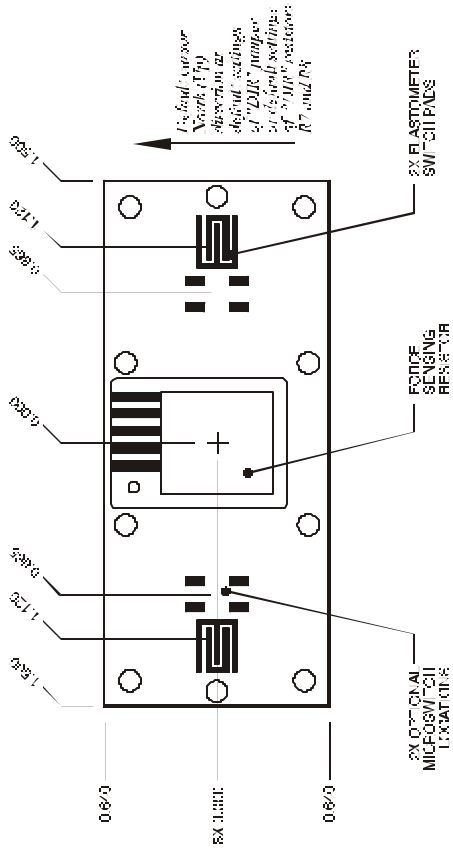

Figure 7.3
Printed Circuit Board Detail

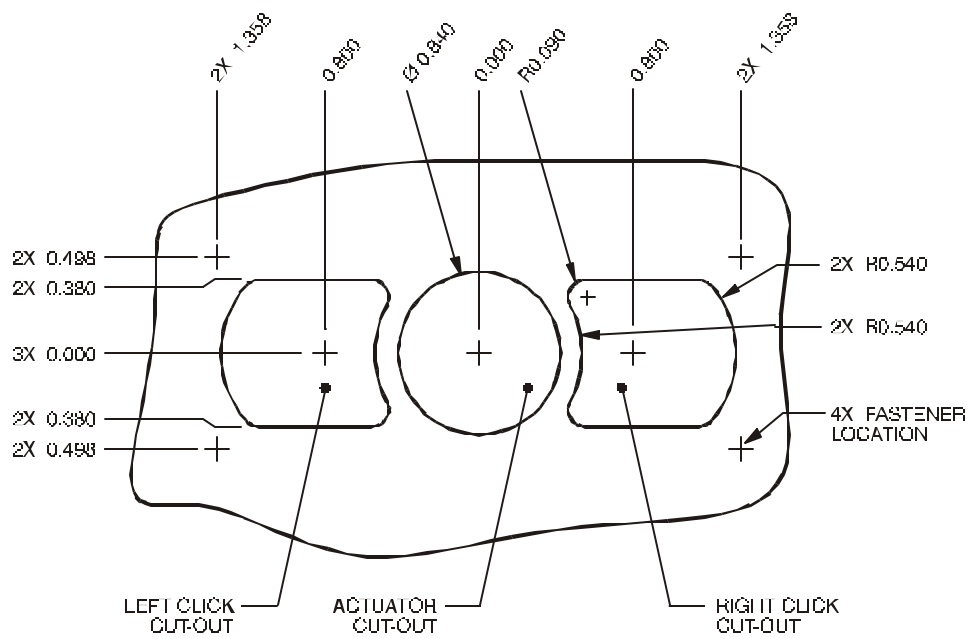

Figure 7.4
Suggested Mounting Cut-out

COM PORT MOUSE DATA FORMAT:

DATA IS TRANSFERRED IN THE FORM OF SEVEN-BIT DATA BYTES, ONE STOP BIT, AND NO PARITY. EACH REPORT CONSISTS OF THREE BYTES. X AND Y ARE RELATIVE MOVEMENTS. X MOVEMENT IS POSITIVE TO THE RIGHT AND NEGATIVE TO THE LEFT. Y MOVEMENT IS POSITIVE IN THE DOWN DIRECTION AND NEGATIVE IN THE UP DIRECTION. MOUSE DATA IS SENT ONLY WHEN THERE IS DATA TO SEND (E.G. MOVEMENT OR BUTTON PRESS/ RELEASE). THE MOUSE REPORTS DATA AT A MAXIMUM RATE OF 40Hz. THE MOUSE WILL TRANSMIT AN "M" WHEN RTS GOES FROM 1 TO 0 (NEGATIVE VOLTAGE TO POSITIVE VOLTAGE). MOUSE DRIVERS USE THIS FEATURE TO DETERMINE WHICH COM PORT, IF ANY, A MOUSE IS CONNECTED TO.

PACKET FORMAT:

BYTE	B6	B5	B4	B3	B2	B1	B0
1	1	L	R	Y7	Y6	X7	X6
2	0	X5	X4	X3	X2	X1	X0
3	0	Y5	Y4	Y3	Y2	Y1	Y0

7 DATA BITS, 1 STOP BIT, NO PARITY
(40 PACKETS PER SECOND MAXIMUM)

L & R = LEFT AND RIGHT CLICK BUTTON DATA.
(1 = KEY DEPRESSED)

X7-X0 = X DISTANCE IN AN 8-BIT TWO'S
COMPLEMENT FORMAT, RANGE -128 TO 127

Y7-Y0 = Y DISTANCE IN AN 8-BIT TWO'S
COMPLEMENT FORMAT, RANGE -128 TO 127

Figure 7.5
Mouse COM Port Output

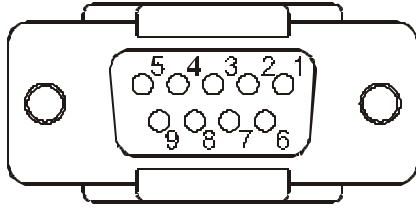

DB-9 PIN LOCATIONS

DB-9 PIN	SIGNAL	SIGNAL DESCRIPTION
1	CLK/CD	CLOCK
2	RXD	RECEIVE DATA
3	TXD	TRANSMIT DATA
4	DTR	DATA TERMINAL READY
5	GND	SIGNAL GROUND
6	N/A	NO CONNECTION
7	RTS	REQUEST TO SEND
8	+5/CTS	+5V
9	DATA/RI	DATA

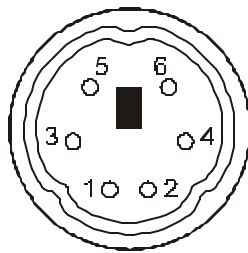

PS/2 PIN LOCATIONS

PS/2 PIN	SIGNAL DESCRIPTION
1	DATA
2	NO CONNECTION
3	GROUND
4	+5 V _{cc}
5	CLOCK
6	NO CONNECTION



USB PIN LOCATIONS

USB PIN	SIGNAL DESCRIPTION
1	V BUS
2	D-
3	D+
4	GROUND
SHELL	SHIELD

Figure 7.6
DB-9, PS/2 and USB Connector Detail

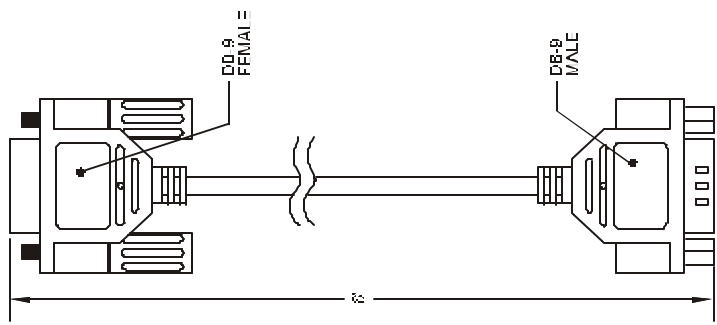

VP660

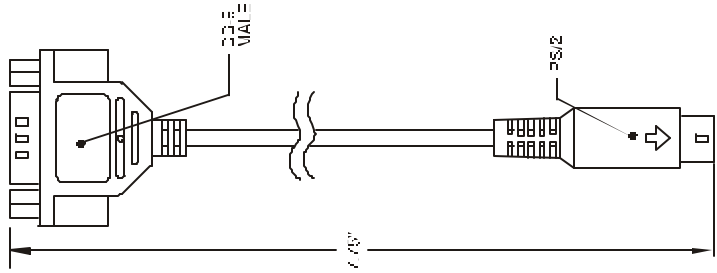

VP650

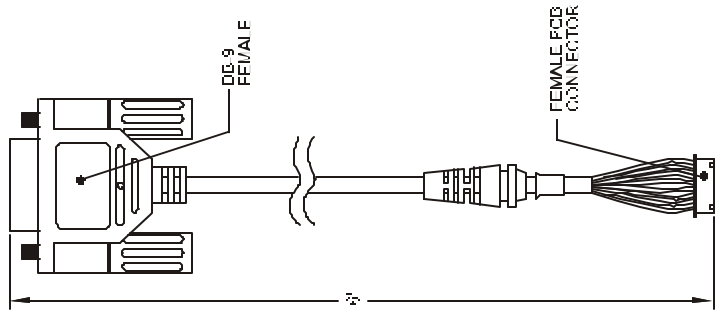

VP640

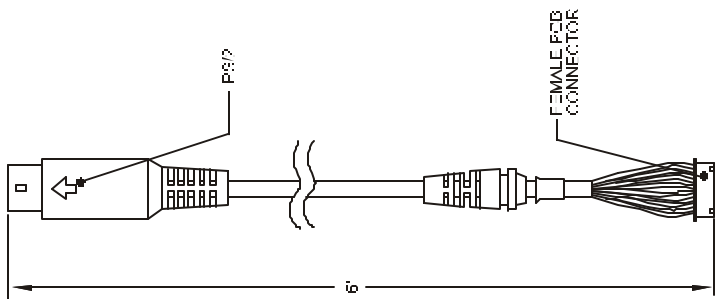

VP630

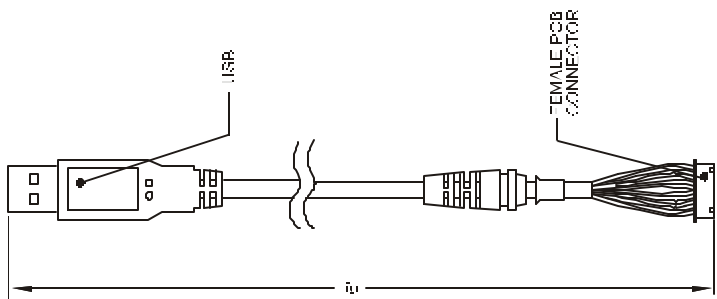

VP615

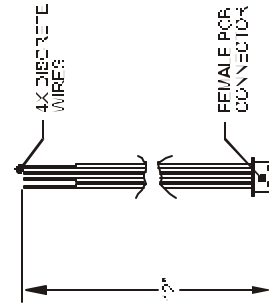

VP820

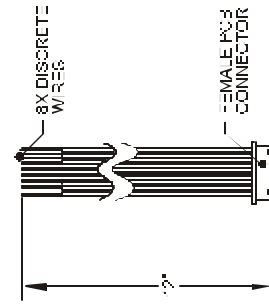

VP810

Figure 7.7
Optional Cable Details

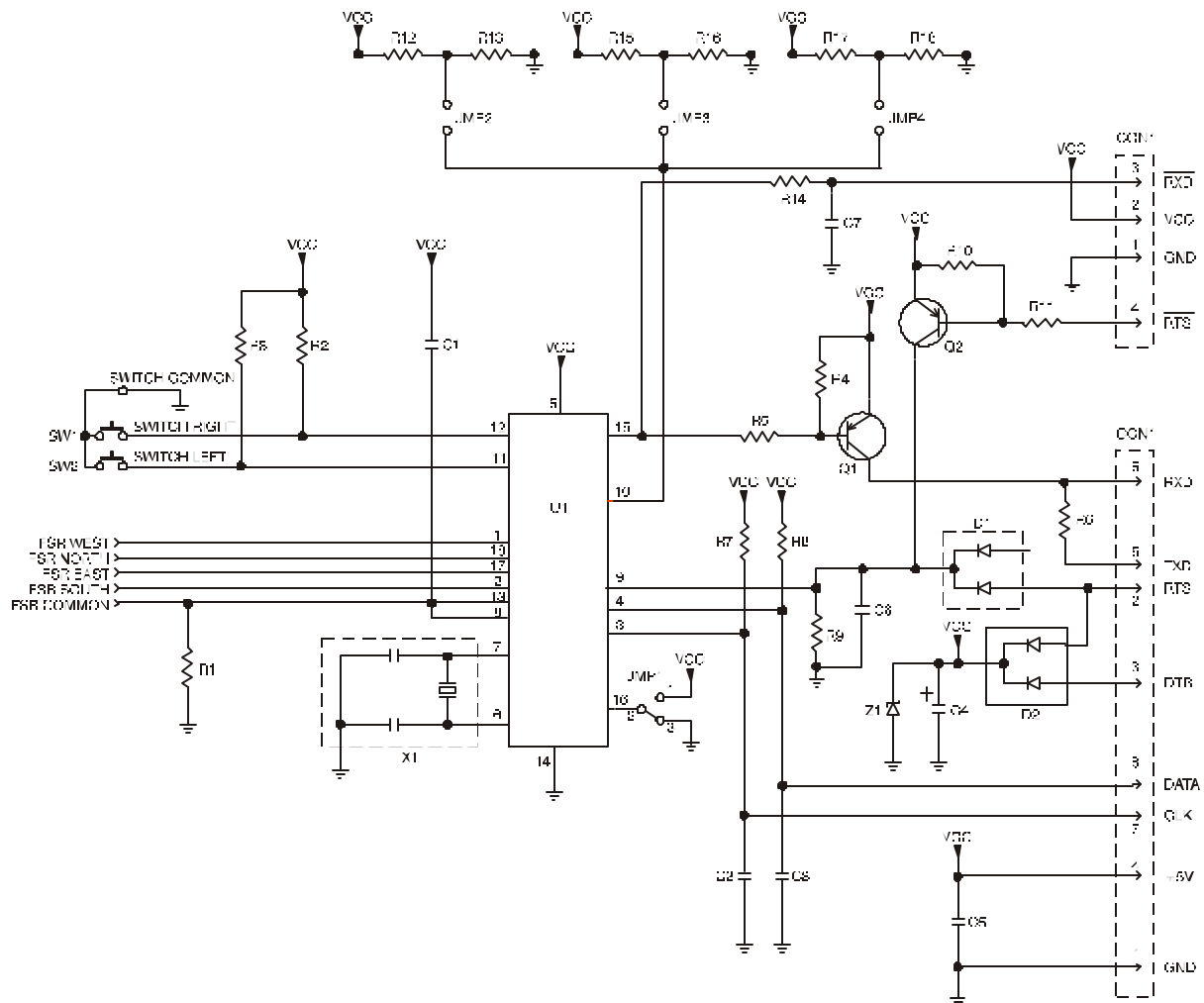

Figure 7.8
MicroModule PCB Schematic

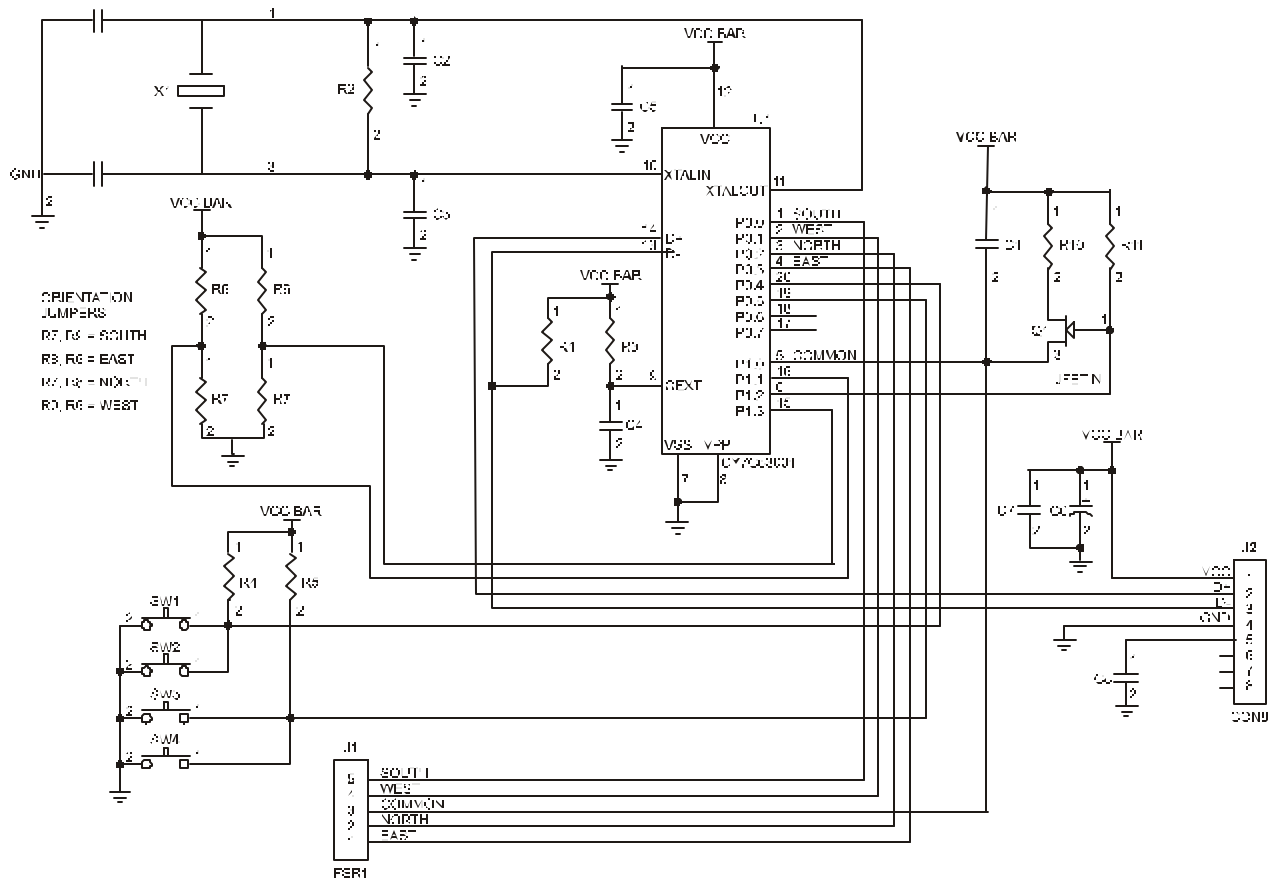

Figure 7.9
USB MicroModule PCB Schematic

8.0 Warranty Information

Interlink Electronics warrants the MicroModule against defects in materials or workmanship for a period of one (1) year after date of purchase. Interlink Electronics will, at its option, repair or replace any MicroModule, which becomes inoperable due to defects of manufacture.

If you need to return a MicroModule for warranty repair and have already contacted Interlink Electronics Product Support to receive an RMA number, pack the MicroModule securely with an explanation of the problem and a copy of the dated Bill of Sale, label the box with the RMA number clearly visible, and send the package prepaid and insured to Interlink Electronics.

Interlink Electronics will ship the repaired or replaced product to you prepaid. Interlink Electronics reserves the right to provide, at no additional cost, a more current or upgraded model for replacement, if available.

9.0 Product Support

MicroModule has been designed for quick and easy integration. However, if you have any questions about integrating or using your MicroModule, please call Interlink Electronics Product Support at:

Interlink Electronics Product Support

Phone: 805-484-1331
Toll free in the US..... 800-340-1331
Fax: 805-484-5997
E-mail: psupport@interlinkelec.com

Product Support hours: 8:00 AM to 5:00 PM
(United States Pacific Standard Time)

Corporate Headquarters

Interlink Electronics
546 Flynn Road
Camarillo, CA 93012 USA

Phone: 805-484-8855
Fax: 805-484-8989

Japan Office

Interlink Electronics KK
2-5-12 Higashi-Kanda
Chiyoda-ku Tokyo, Japan 101-0031

Phone: 81-3-3863-6493
Fax: 81-3-3863-6442

Web Site

www.interlinkelectronics.com